

QMP Dust Systems

~ Serving The Rock Drilling Industry Since 1990 ~

DC-AIR25

- ~ Lightweight @ 45 lbs
- ~ Compact Design
- ~ Low Air Consumption @ 28 CFM
- ~ High Suction Capacity
- ~ Reverse Air Filter Cleaning
- ~ Discharge Into 5-Gallon Bucket or Bag
- ~ Easy Filter Accessibility

Filter Details - One Required

- ~ Large Filter Area @ 25 sq.ft.
- ~ Efficiency: 100% @ 4.0 micron
- ~ Washable, Reusable Filters

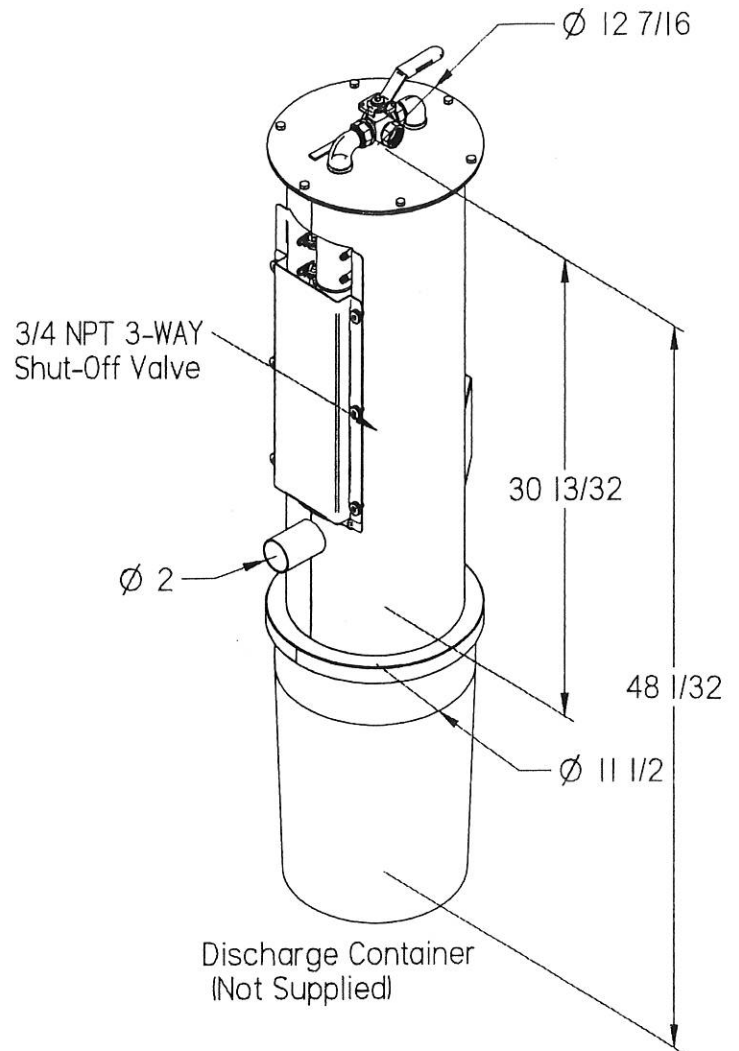

Product Summary

The QMP line of pneumatically driven Dust Collectors are designed for maximum efficiency, durability, and ease of operation. These lightweight collectors are ideal for drilling and breaking applications where dry dust collection is required. Their size and capacity make them very adaptable for many smaller and mobile applications.

Our custom designed filters are built to hold up under tough conditions and are washable and re-usable, extending filter life. Filter cleaning is accomplished by reverse air flushing to insure maximum performance during operation.

Cuttings can be discharged into a standard 5 gallon container or bagged for easy disposal.

UNLESS OTHERWISE SPECIFIED		QMP CORPORATION
STD MACHINING TOLERANCE: XX = +/- 0.03 XXX = +/- 0.015 XXXX = +/- 0.005 XXXXX = +/- 0.0005 FRACTIONAL = +/- 1/32	FAB TOLERANCE: ANGLE = 1° WELD = 1/16" SHEAR = 1/32"-LINEAR ± 1/16"-DIAG LASER = 0.005" PLASMA = 1/32" ± 1" THK, ± 1/16" - 1" THK SAW = 1/32" ASSEMBLY TOLERANCE VARIES 1/8" UP TO 1"	
Model Number	Part Number	
DC-AIR25	170005	